

[CONTRIBUTION FROM THE CHEMICAL LABORATORIES OF HARVARD UNIVERSITY AND RADCLIFFE COLLEGE]

The Normal Electrode Potential of Cesium<sup>1</sup>

BY HENRY E. BENT, GEORGE S. FORBES AND A. F. FORZIATI

The normal electrode potential of sodium was the first of the alkali metals to be determined. Lewis and Kraus<sup>2</sup> measured the potential of sodium against a dilute sodium amalgam using sodium iodide in ethylamine as the electrolyte. Thanks to overvoltage, it was possible to compare the same amalgam under a water solution with a standard electrode. From the sum of the two e. m. f. values the normal electrode potential  $E^0$  for sodium against a "hypothetical molal solution" of sodium ion in water was calculated. Taking  $E^0$  for hydrogen as zero,  $E^0$  for sodium becomes 2.7125 volts at 25°. Values of  $E^0$  for potassium,<sup>3</sup> lithium,<sup>4</sup> and rubidium,<sup>5</sup> 2.9224, 2.9578, and 2.9242 volts, respectively, were subsequently obtained by similar methods. The apparent paradox that  $E^0$  for lithium was the highest of the four was explained<sup>5</sup> in terms of hydration of the ions involved. The method proved unsuccessful with cesium<sup>6</sup> "as no solvent could be found for a salt of cesium which would not dissolve the metal." Later Gilfillan<sup>7</sup> in the laboratory of one of us (H. E. Bent) entertained the idea that cesium triphenylmethyl dissolved in diethyl ether might prove to be an electrolyte suitable for use in a cesium-cesium amalgam cell. But since the corresponding potassium cell yielded erratic electromotive force values, measurements involving cesium were not undertaken.

Of the efforts to calculate  $E^0$  for cesium from other data, two deserve especial mention. Makishima<sup>8</sup> discussed a cyclic process in which solid cesium is vaporized, the vapor ionized, the gaseous ions hydrated and then reconverted to cesium through an electrode reaction. His elaborate calculations predicted  $E^0 = 2.922$  volts at 25°. Certain of his assumptions, however, have been criticized by Lange and Nagel.<sup>9</sup>

Latimer<sup>10</sup> calculated  $E^0$  for all the alkali metals from the heats of formation of their aqueous ions and the entropy changes in the electrode reactions. He gives the values:

	Li	Na	K	Rb	Cs
$E^0$ calcd., v.	3.06	2.72	2.93	2.99	3.04
$E^0$ exp., v.	2.957	2.712	2.922	2.924	..

Lewis and Argo<sup>5</sup> had predicted the reverse order for lithium and cesium.

**The Electrolyte.**—Bent and Swift<sup>11</sup> showed that dimethylamine, which dissolves sodium iodide quite freely, reacts very slowly with sodium or dilute sodium amalgams. This electrolyte also proved successful in cells involving concentrated sodium amalgams.<sup>12</sup> Preliminary experiments on the conductivity of cesium iodide in dimethylamine followed, employing an apparatus similar to those of Bent and Swift.<sup>11</sup> These proved so encouraging that materials were purified for definitive measurements. The treatment of dimethylamine has been described.<sup>12</sup> A sample of cesium iodide, many times recrystallized,<sup>13</sup> was kindly furnished by Professor Grinnell Jones of this Laboratory. Crude cesium metal, sealed in small evacuated ampoules, was donated by the General Electric Company. One of these, together with a magnetic hammer, was sealed into a stout Pyrex tube connected with a train of four small bulbs. In a high vacuum this ampoule was crushed, and the cesium (about one gram) was distilled into the bulbs successively, leaving behind about 0.05 g. in each bulb to eliminate the other (less volatile) alkali metals. A single distillation required about ten hours at 200° and twenty at 150°. Dross was observed in the initial container only, and the distilled metal, while liquid, looked much like mercury. Thrice distilled samples, only, were used in the following experiments.

**The conductivity cell,** an all-glass apparatus of novel design, is shown in Fig. 1. After thorough evacuation by a mercury diffusion pump

(1) This problem, proposed by H. E. Bent and begun in 1936 by H. E. B. and A. F. F., was completed, 1936-1938, by G. S. F. and A. F. F. The experimental work was carried out by Mr. Forziati while assistant at Radcliffe College.—G. S. F.

(2) Lewis and Kraus, *THIS JOURNAL*, **32**, 1459 (1910).

(3) Lewis and Keyes, *ibid.*, **34**, 119 (1912).

(4) Lewis and Keyes, *ibid.*, **35**, 340 (1913).

(5) Lewis and Argo, *ibid.*, **37**, 1990 (1915).

(6) Bent and Hildebrand, *ibid.*, **49**, 3011 (1927).

(7) Gilfillan, Thesis, Harvard University, 1932.

(8) Makishima, *Z. Elektrochem.*, **41**, 697, 708, 710 (1935).

(9) Lange and Nagel, *ibid.*, **42**, 54 (1936).

(10) Latimer, "Oxidation Potentials," Prentice-Hall Book Co., New York, 1938, p. 284.

(11) Bent and Swift, *THIS JOURNAL*, **58**, 2216 (1936).

(12) Bent and Forziati, *ibid.*, **58**, 2220 (1936).

(13) Jones and Fornwalt, *ibid.*, **58**, 619 (1936).

connected through a trap cooled with dry-ice, the dimethylamine already distilled three times in an apparatus flamed and pumped out, was admitted into the tube A. The connecting tube was sealed off, and the solvent was decanted into the conductivity cell C. A potentiometer serving as

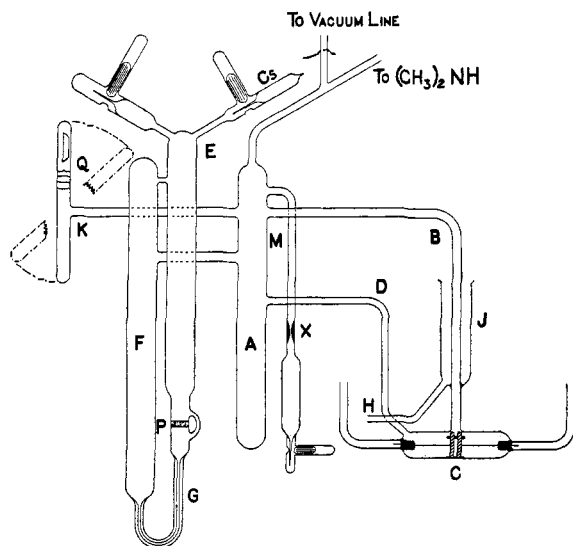

Fig. 1.—Apparatus for preparing solutions of cesium iodide in  $(\text{CH}_3)_2\text{NH}$  and measuring their conductivities.

a source of variable known voltage was adjusted until the deflection of a galvanometer, in series with a Shallcross resistor of one million ohms, was just ten millimeters. By means of a double-throw switch of special design, the cell was substituted<sup>14</sup> for the resistor and the deflection read again. The liquid was now transferred to A and then to F, from which it flowed through the capillary G and the sintered glass plug P upon which a globule of cesium had been poured from a capsule attached at E, after breaking a capillary inner seal. Table I gives the specific conductivity of pure dimethylamine, and of the solution formed upon contact with cesium with increasing time, showing that cesium is essentially stable in contact with dimethylamine.

DIMETHYLAMINE TREATED WITH CESIUM	
Time, min.	Specific conductivity, mhos
0	$4.4 \times 10^{-10}$
10	$1.9 \times 10^{-10}$
30	$4.0 \times 10^{-9}$
210	$6.0 \times 10^{-9}$
1200	$6.8 \times 10^{-9}$

From cell C the liquid was transferred back to F but upon cooling A in dry-ice, pure dime-

(14) Bent and Keevil, *THIS JOURNAL*, **60**, 193 (1938).

thylamine collected in A. A boat containing fused cesium iodide had thus far remained in the horizontal tube Q in contact with dimethylamine vapor. This boat was now tipped into A and shaken mechanically overnight. That saturation was attained appears from the fact that the specific conductivity  $\kappa \approx 1 \times 10^{-8}$  mho at  $20^\circ$  did not further increase during the following day. Even this low conductivity would have been sufficient for e. m. f. measurements. This solution was next treated in P with cesium metal, whereupon  $\kappa$  increased over 400 minutes to a maximum of  $4 \times 10^{-8}$  mho. The above experiment repeated at  $30^\circ$  gave  $3.8 \times 10^{-8}$  mho for the dimethylamine saturated with cesium iodide. But in contrast with the comparative stability of solid cesium in contact with the solvent at  $20^\circ$ , the whole of a half-gram globule dissolved at  $30^\circ$  within thirty minutes, turning the 50-cc. sample of liquid a deep greenish-brown. Evidently measurements above the melting point of cesium,  $28.5^\circ$ , would be vitiated by the rapid reaction between solution and metal.

**Cesium-Cesium Amalgam Cells.**—About half a liter of cesium amalgam was prepared by electrolysis of cesium sulfate over a mercury cathode in a vessel so designed that the amalgam could be drawn off into an evacuated container without access of air. Portions of the same sample were used in all our cells. The mercury had been elaborately purified by sulfuric acid and air, nitric acid, a mercurous nitrate tower, two distillations in air and two with high vacuum technique. The last of these distillations introduced the mercury into an evacuated vessel with an inner capillary seal.

Three different cells were evolved, each reflecting the improvements suggested by previous difficulties. Cells I and II contained the amalgam in a shallow annular compartment surrounding a pellet of cesium metal, so as to keep the resistance of the current path at a minimum. Unfortunately a trace of mercury distilled from the amalgam to the metal before introduction of electrolyte, dulling the surface of the cesium. In addition, the electrolyte worked its way between the cesium pellet and the platinum wire imbedded in it so that the pellet was finally detached. As a result, the measurements were erratic. Both these difficulties were eliminated in cell III (Fig. 2), which also embodied the principles for transfer of materials common to all three cells. The

compartment for cesium, the right limb of the H-tube, was protected from mercury vapor by a porous sintered Pyrex disk. The long capillary at the base of this compartment made the sealed in platinum wire at its base inaccessible to solvent. A saturated solution of cesium iodide in dimethylamine was prepared in the conductivity apparatus as described above and from this apparatus decanted into a special container provided with a capillary inner seal through which it was fused to the cell before evacuation of the latter. Cesium and cesium amalgam were originally present in two other containers similarly separated from the cell. The three capillary inner seals were subject to breakage, in appropriate order, with magnetic hammers. An essential feature is the special by-pass between the limbs of the cell above the liquid, by which gas pressure was equalized.

The entire cell was baked out at 450° overnight on the mercury diffusion pump. A trap at -78° condensed any vapor escaping from the pump. The cesium metal was first introduced, the amalgam followed, and then the cell was sealed off from the line. The saturated solution of cesium iodide in dimethylamine was transferred to the reservoir diagonally attached to the cell, and the previous container sealed off. The system was now brought to zero in a very large ice-bath, after which the solution was decanted into the cell. Readings of e. m. f. were begun immediately.

These measurements, extending over a period of two weeks for each cell, were made upon a Leeds and Northrup type K potentiometer; the sensitivity of the galvanometer was 10<sup>-10</sup> ampere per mm. The standard cadmium cell was checked against one recently certified by the Bureau of Standards. A large tub was subject to thermostatic control at any desired temperature. Repeated readings of e. m. f. were made at zero and at five-degree intervals up to 25.00 ± 0.05°. Further readings were then made at the same points back to zero, then back to 25° and so on. Cell II was finally investigated at 30.0 and 35.0°, giving rough data for liquid cesium.

Table II gives averaged data for cells I and II. The third column shows the difference between the highest and lowest value at a specified temperature. The data for cell III are given separately in Table III as evidence of its superiority. Emphasis is laid upon the high stability of the system over a long period of time. The last column, *a*<sub>Cs</sub>, is the activity of cesium, referred to

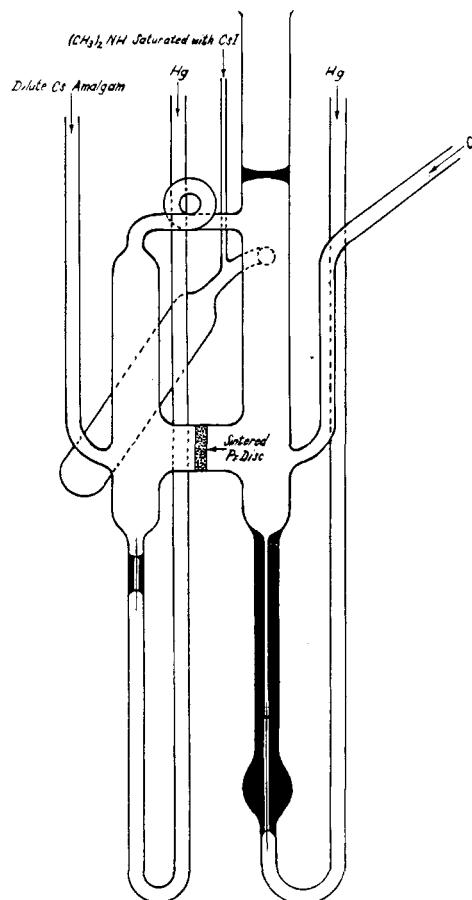

Fig. 2.—Cesium-cesium amalgam, cell III.

TABLE II  
CESIUM AGAINST CESIUM AMALGAM, CELLS I AND II

°C.	E. m. f., volts	Max. diff., volt	Number of readings
0	1.168	0.0102	15
5	1.149	.0253	40
10	1.146	.0084	12
15	1.135	.0113	41
20	1.124	.0105	11
25	1.105	.0800	78
30 <sup>a</sup>	1.104	.0093	20
35 <sup>a</sup>	1.087	.0090	6

<sup>a</sup> Liquid cesium.

TABLE III  
CESIUM AGAINST CESIUM AMALGAM

°C.	Cell III, e. m. f., volt	Max. diff., volts	Number of readings	Weighted average of I, II, III	E. m. f. from best straight line	<i>a</i> <sub>Cs</sub>
0	1.159	0.0102	62	1.161	1.164	3.3 × 10 <sup>-22</sup>
5	1.157	.0091	85	1.155	1.155	1.2 × 10 <sup>-21</sup>
10	1.147	.0076	18	1.147	1.146	4.0 × 10 <sup>-21</sup>
15	1.141	.0057	24	1.140	1.137	1.3 × 10 <sup>-20</sup>
20	1.130	.0048	15	1.129	1.128	4.0 × 10 <sup>-20</sup>
25	1.121	.0073	19	1.118	1.119	1.2 × 10 <sup>-19</sup>
30	...	...	..	1.104	1.107	3.9 × 10 <sup>-19</sup>
35	...	...	..	1.087	1.086	1.7 × 10 <sup>-18</sup>

the activity of solid cesium at the same temperature as unity, in 0.2827 atom per cent. cesium amalgam (analyzed by the method of Bent and Swift<sup>11</sup>).

Cells of the type Cs amalgam/CsOH aq/HgO/Hg, which had no liquid junction when first set up, were next investigated. The electrode reactions are

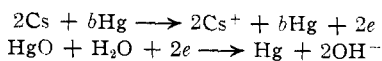

also the minor side reaction

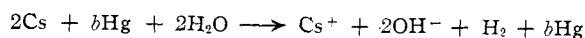

Cesium hydroxide solution was prepared from thrice distilled cesium and conductivity water redistilled with complete exclusion of air, in the apparatus shown in Fig. 3. After complete

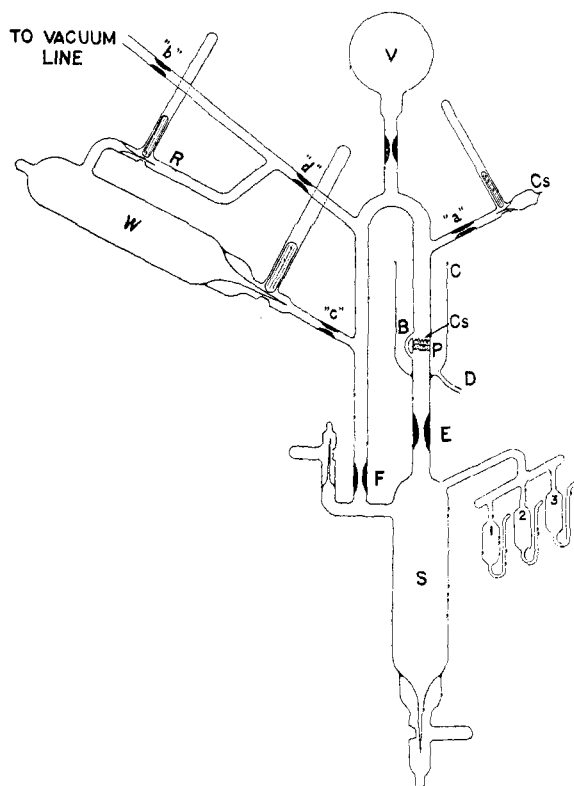

Fig. 3.—Apparatus for preparing cesium hydroxide solutions.

exhaustion the cesium capsule was opened, and upon gentle warming the cesium flowed down upon the porous plug P. After sealing off the capsule at "a," the assembly was sealed off from the vacuum line at "b," and the water (W) admitted to S. Upon cooling jacket C, water vapor condensed quite rapidly upon the metal, forming cesium hydroxide solution which passed through

the porous plug and down into S. Bulb V served to keep hydrogen pressure below one atmosphere. Otherwise it would have been impossible to seal off the tubes at E and F after completion of the reaction.

The apparatus was vigorously shaken, and then sample tubes 1, 2, and 3 were filled and sealed off. Titrated with standard acid, the cesium hydroxide concentration  $C_0$  was found to be  $0.02109 \pm 0.00004$  weight normal.

Several samples of mercuric oxide were prepared by anodic oxidation of mercury under sodium hydroxide, and several by ignition of mercuric nitrate. This nitrate was made by treating our purest mercury with redistilled nitric acid. In a special four-electrode cell the various samples were intercompared. The pyrolytic samples agreed within 0.00002 volt, but the electrolytic samples showed divergences from the pyrolytic and from each other often amounting to 0.002 volt, decreasing somewhat with time. Therefore pyrolytic samples exclusively were used in the cells.

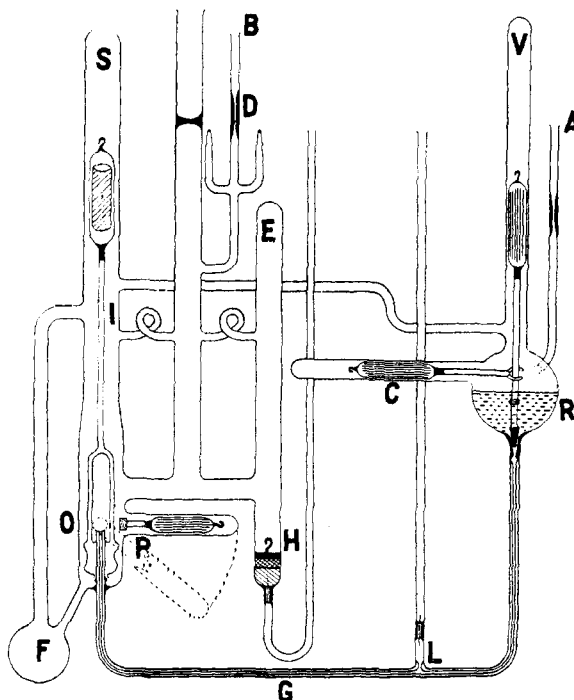

Fig. 4.—Cesium amalgam-mercuric oxide cell.

The structural features of the cell appear in Fig. 4. The capsule for cesium amalgam was attached at A, and that for cesium hydroxide at B. Before sealing E, mercury and then mercuric oxide were introduced through a long funnel tube.

After removing the funnel tube, a sintered Pyrex plug H was lowered into place by means of a long glass hook. Tube E was then sealed and the system evacuated. A cloth jacket containing dry-ice was wrapped around tube E, about 25 cm. above the level of the oxide. To remove adsorbed air the mercury and mercuric oxide were heated cautiously until a thin film condensed on the cooled portions of the tube. After removal of the jacket the system was exhausted for forty-eight hours, with occasional local heating by means of a hand torch. After testing for leaks two solenoids (not shown) were slipped over tubes C and V.

The capsule above A was opened and the amalgam (about 100 cc.) flowed into reservoir R. The tube was then sealed off. By energizing the solenoid above V the valve at the base of R was unseated until the capillary G and the pocket L were filled with amalgam. The cell was sealed off from the vacuum line and solution admitted into the cell, after which a seal was made at D.

After thermostating at  $5^{\circ}$ , the stirrer S was set in motion by a double-wound solenoid over S. The current flowed continuously through the bottom winding so that the stirrer could not strike the bottom of the compartment. By automatically making and breaking the current in the upper winding about twice a second the stirrer was made to oscillate in corresponding fashion. Solution circulated through the stirrer, spurting out at I.

The assembly had been mounted on a horizontal rod (not shown) clamped to a horizontal swivel so that the difference in height between the amalgam levels in R and O, respectively, could now be altered to secure the desired flow from the orifice at O after unseating the valve at the base of R. The clamp at C, magnetically controlled, held the valve wide open as long as desired. Whenever drops of amalgam adhered to the edge of the capillary at O, they were dislodged by electromagnetic operation of the plunger P. This plunger was actually at right angles to the plane of the paper, as is suggested by the dotted lines. The used amalgam collected in the sump at F, so that the cesium ion formed by its action on water could not greatly increase the concentration of that ion at O. If the rate of flow was made less than one drop in two seconds, the e. m. f. fell off. The e. m. f. at one drop per second could not be increased by further increase in the rate of flow.

This rate was therefore adopted for all the measurements.

Measurements on cell I were obtained at  $5^{\circ}$  only, because a cast metal clamp snapped, breaking the cell at L. The cell was repaired and refilled (cell II). The amalgam flow was interrupted only while the temperature (of cell II) was being changed, in five-degree intervals from  $0$  to  $30^{\circ}$  and back to  $0^{\circ}$  again. From three to nine readings were taken at each temperature. Results (for cell II) in Table IV were obtained in 10.7 hours of continuous operation of which amalgam flowed for 3.5 hours.

Immediately after conclusion of the measurements of cell II, the solution was pipetted off down to the bottom of the cross arm. The portions remaining in H, O, and F were then withdrawn separately, also the unimportant amount which had condensed upon the surface of the amalgam in R. All these samples were weighed and their content in cesium hydroxide determined.

The actual readings of e. m. f. are summarized in Table IV. The later readings at any given temperature are in all cases depressed, due to gradual increases in cesium hydroxide concentration. We assumed for lack of pertinent information, that the increase, at a given electrode at any fixed temperature, is proportional to time; also that its rate is doubled by each ten degree rise in temperature. We refrained from efforts to evaluate by trial an arbitrary exponent which would bring about an optimum agreement between corrected values with ascending and descending temperatures, respectively. Let  $x$  be the increase in moles of cesium hydroxide per hour at  $0.0^{\circ}$  in the amalgam compartment. The total increase over 10.7 hours will be in the form

$$\Sigma \left[ x \left( \log^{-1} \frac{0.301(T - 273)}{10} \right) t_T \right] = 0.00513 \text{ mole}$$

from which  $x$  can be calculated. The increase from zero time up to any other time,  $t$ , is then found by carrying the summation as far as time  $t$  only. The increase in moles of cesium hydroxide in the mercuric oxide compartment up to the time  $t$  is found in similar fashion from the total increase, 0.00430 mole in 10.7 hours. For the particular volume in a given compartment the ratio of moles present at two given times equals the ratio of concentrations. Corrected concentrations over cesium amalgam and mercuric oxide, respectively, are  $C'$  and  $C''$ .

TABLE IV  
 CESIUM AMALGAM AGAINST MERCURIC OXIDE ELECTRODE

°C.	Time elapsed, hours	Obsd. e. m. f., volts	Maximum diff., volt	C'	$\frac{RT}{F} \ln \frac{C' \gamma'}{C^0 \gamma^0}$	C''	$\frac{RT}{2F} \ln \frac{(C'' \gamma'')^2}{(C^0 \gamma^0)^2}$	Concn. gradient potential	E. m. f., corrected
5.0	0.00	2.0800	0.0074	0.02109	0.00025	0.02109	0.00020	0.00000	2.0800
5.0	1.00	2.0799	.0010	.02131	.00027	.02127	.00023	.00002	2.0804
2.0	1.30	2.0772	.0003	.02136	.00031	.02132	.00026	.00002	2.0777
0.0	1.55	2.0747	.0014	.02140	.00057	.02135	.00046	.00002	2.0753
5.0	2.55	2.0800	.0004	.02162	.00081	.02153	.00066	.00004(5)	2.0811
10.0	3.30	2.0863	.0001	.02185	.00123	.02172	.00103	.00006	2.0878
15.0	4.13	2.0930	.0006	.02221	.00187	.02203	.00157	.00009	2.0954
20.0	5.13	2.0964	.0025	.02282	.00292	.02254	.00245	.00013	2.1000
25.0	6.30	2.1003	.0002	.02379	.00397	.02336	.00333	.00020(5)	2.1059
30.0	7.10	2.1040	.0010	.02477	.00432	.02418	.00363	.00028	2.1116
25.0	7.60	2.0983	.0003	.02521	.00465	.02454	.00391	.00030	2.1066
20.0	8.30	2.0925	.0002	.02564	.00473	.02490	.00399	.00032	2.1014
15.0	8.70	2.0867	.0006	.02581	.00476	.02505	.00399	.00033	2.0958
10.0	9.10	2.0800	.0006	.02593	.00477	.02515	.00402	.00032(5)	2.0891
5.0	9.70	2.0725	.0005	.02606	.00482	.02526	.00407	.00033	2.0816
0.0	10.70	2.0670	.0002	.02621		.02539		.00033	2.0762

Table IV shows evaluation of corrections based on activities for the two electrodes, respectively, which must both be added to observed readings of e. m. f. to obtain the readings which would have been obtained if concentration had remained constant at its initial value, 0.02109 weight normal. There was a small additional correction to the e. m. f. due to the concentration gradient between the two electrodes, which was calculated with sufficient accuracy by the Nernst equation (column 9). The fact that the last fully corrected reading at each temperature so nearly equals the first, indicates alike the reproducibility of our data and the soundness of our method of correction.

°C.	E. m. f., volts
0	2.0754
5	2.0815
10	2.0876
15	2.0937
20	2.0997
25	2.1058
30	2.1118

By adding corresponding e. m. f. values for the two types of cells, the e. m. f. of the hypothetical aqueous cell Cs/CsOH (0.02109 wt. normal)/-HgO/Hg (Table VI, column 2) was obtained. This cell must next be recalculated to unit activity of CsOH. Harned and Schupp<sup>15</sup> give the following data at 25° only:  $\gamma = 0.879$  at  $N = 0.02044$  and  $\gamma = 0.866$  at  $0.02541$ . By linear interpolation  $\gamma = 0.877$  at  $N = 0.02109$  weight

(15) Harned and Schupp, *THIS JOURNAL*, **52**, 3886 (1930).

normal at the same temperature. To obtain  $\gamma$  at the other temperatures it was assumed that the temperature coefficient of  $\gamma$  for CsOH was identical with that of KOH<sup>16</sup> in the same range. Omitting details of calculation we have

t, °C.	0	5	10	15	20	25	30
$\gamma$	0.8815	0.881	0.8805	0.8795	0.8785	(0.877)	0.8755

Table VI shows the corrections which must be applied to the respective electrodes to convert them both to unit activity of cesium hydroxide.

 TABLE VI  
 CORRECTING TO CsOH AT UNIT ACTIVITY

°C.	$E_{\text{cell}}(\text{hypoth.})$	$a_{\text{CsOH}}$	$\frac{RT}{F} \ln a_{\text{Cs}^+}$	$-\frac{RT}{2F} \ln (a_{\text{OH}^-})^2$
0	3.2394	0.01859	-0.0938	0.0938
5	3.2365	.01858	-.0955	.0955
10	3.2336	.01857	-.0973	.0973
15	3.2307	.01855	-.0990	.0990
20	3.2277	.01853	-.1008	.1008
25	3.2248	.01849	-.1025	.1025
30	3.2188	.01846	-.1043	.1043

To obtain the normal electrode potential of cesium, the normal potential of the mercuric oxide electrode must be known at each of our temperatures.  $E^0$  (for red mercuric oxide) as given in the "International Critical Tables,"<sup>17</sup> at 25°, is -0.0969 volt referred to the normal hydrogen electrode as zero. We abstain from a critical discussion of the possibilities of error in this value. Should a different figure be agreed upon at some future time, our values for the normal electrode potential of cesium readily can be adjusted to it.

(16) Harned and Cook, *ibid.*, **59**, 496 (1937).

(17) "International Critical Tables," Vol. VI, p. 332.

The same holds for Donnan and Allmand's<sup>18</sup> temperature coefficient  $-0.00011$  volt/degree.

In Table VII by subtraction of the normal potential of the mercuric oxide electrode from that of our hypothetical corrected cell, the normal electrode potential of cesium is evaluated for each temperature.

TABLE VII  
THE NORMAL ELECTRODE POTENTIAL OF CESIUM

°C.	$E^0_{\text{cell(hypoth.)}}$ $a_{\text{CsOH}} = 1.000$	$E^0_{\text{Hg, HgO}}$	$E^0_{\text{Cs metal, Cs}^+}$ volts
0	3.0518	-0.0997	2.952
5	3.0455	- .0991	2.946
10	3.0390	- .0986	2.940
15	3.0327	- .0980	2.935
20	3.0261	- .0975	2.928(5)
25	3.0198	- .0969	2.923
30	3.0102	- .0964	2.914

From the Gibbs-Helmholtz equation, there follow three enthalpy changes,  $\Delta H_1$  for transfer of one gram atom of cesium from the solid metal to the amalgam, 0.2827 atom per cent. cesium;  $\Delta H_2$  for the reaction

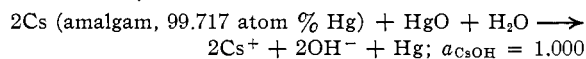

and  $\Delta H_3$  for the reaction

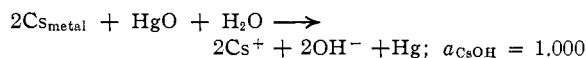

all in  $15^\circ$  kilocalories.

TABLE VIII

Average $dE/dT$ from $0-25^\circ\text{C}$ .	Enthalpy change (kilogram calories)	Free energy change at $25^\circ$ (kilogram calories)
$-0.00180$	$\Delta H_1 = -38.2$	$\Delta F_1 = -25.8$
$+ .00052$	$\Delta H_2 = -80.53$	$\Delta F_2 = -87.69$
$- .00128$	$\Delta H_3 = -156.9$	$\Delta F_3 = -139.3$

(18) Donnan and Allmand, *J. Chem. Soc.*, **99**, 845 (1911).

We acknowledge our indebtedness to the General Electric Company for three grams of cesium metal, and to Professor Grinnell Jones for an adequate supply of very pure cesium iodide.

### Summary

The cells Cs / CsI in  $(\text{CH}_3)_2\text{NH}$  / Cs amalgam and Cs amalgam / CsOH aq / HgO, Hg were studied at various temperatures using special apparatus and methods required by the high reactivity of cesium.

Cells of the former type were stable within a few millivolts for two weeks or more. Those of the second type, using a flowing amalgam, were subject to a gradual increase in concentration of cesium hydroxide which was determined analytically over each electrode. Given the activity coefficient of cesium hydroxide at each concentration at each temperature, the proper correction at each electrode and at each time was calculated. The e. m. f. thus corrected was reproduced, on the average, within one millivolt upon returning to any given temperature.

From the corrected data,  $E^0$ , the normal electrode potential of solid cesium at  $0, 5, 10, 15, 20$  and  $25^\circ$  was obtained. That of liquid cesium is found at  $30^\circ$  only.

In addition, the activity of cesium in 0.2827 atom per cent. cesium amalgam at each temperature, also enthalpy changes and free energy changes for each of three reactions are evaluated.

Among the data given, those of most interest are perhaps  $E^0$  for cesium at  $0$  and  $25^\circ$ , 2.952 volts and 2.923 volts, respectively, very close to the corresponding value for rubidium, but still thirty-four millivolts below that for lithium.

CAMBRIDGE, MASS.

RECEIVED JANUARY 28, 1939